

PIEZO ELEMENT SPECIFICATIONS

MODEL AW5E27T-690E

Resonant frequency	F_r	$69.0 \pm 5.0 \text{kHz}$
Resonant impedance	R	$500 \Omega \text{ MAX.}$
Main electrostatic capacity	C_m	$3500 \pm 30\% \text{ pF at } 1000\text{Hz}/1\text{V } 25^\circ\text{C}$
Metal plate material		Brass
Metal plate length	mm	27.0 ± 0.1
Metal plate width	mm	2.0 ± 0.1
Metal plate thickness	mm	0.10 ± 0.02
Ceramic length	mm	20.0 ± 0.30
Total height	mm	0.26 ± 0.05
Insulation resistance		$100\text{M} \Omega \text{ MIN. at } 50\text{V}$
Maximum input voltage		$30\text{V}_{\text{p-p}}$
Operating temperature range		$-20^\circ\text{C to } +70^\circ\text{C}$
Storage temperature range		$-30^\circ\text{C to } +80^\circ\text{C}$

APPEARANCE AND DIMENSIONS:

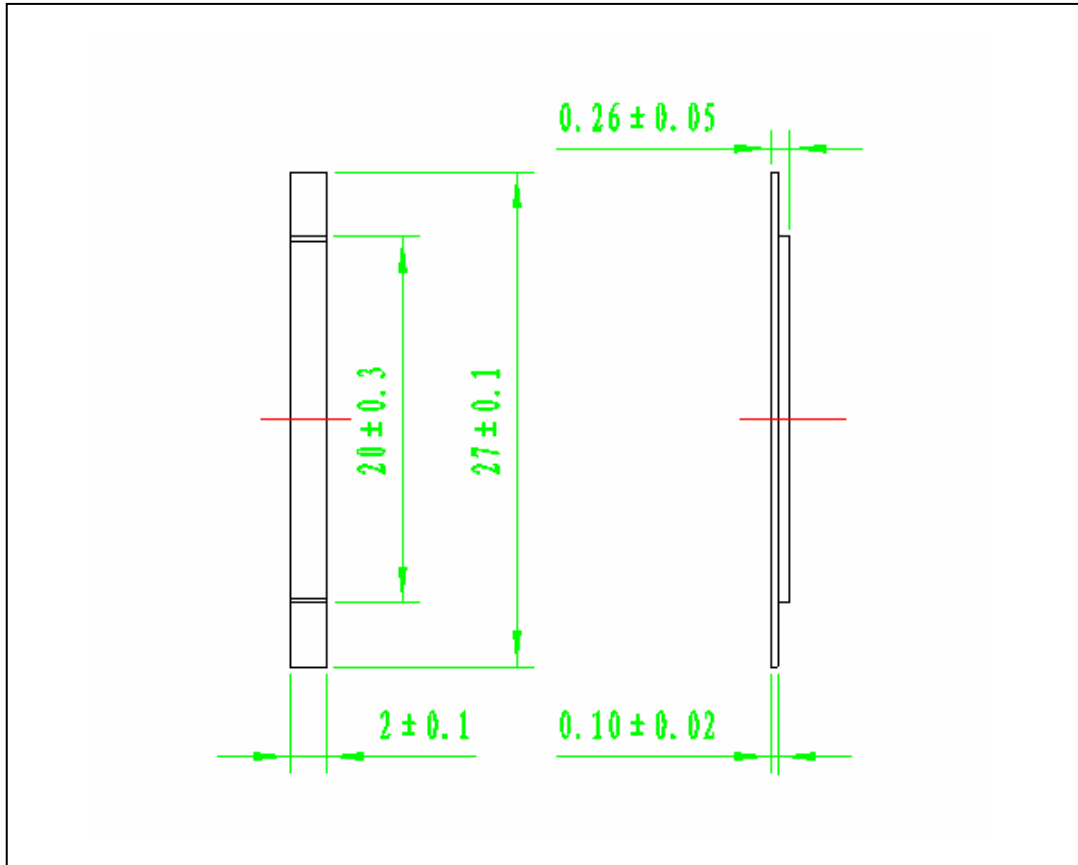

■ TYPICAL FREQUENCY RESPONSE CURVE

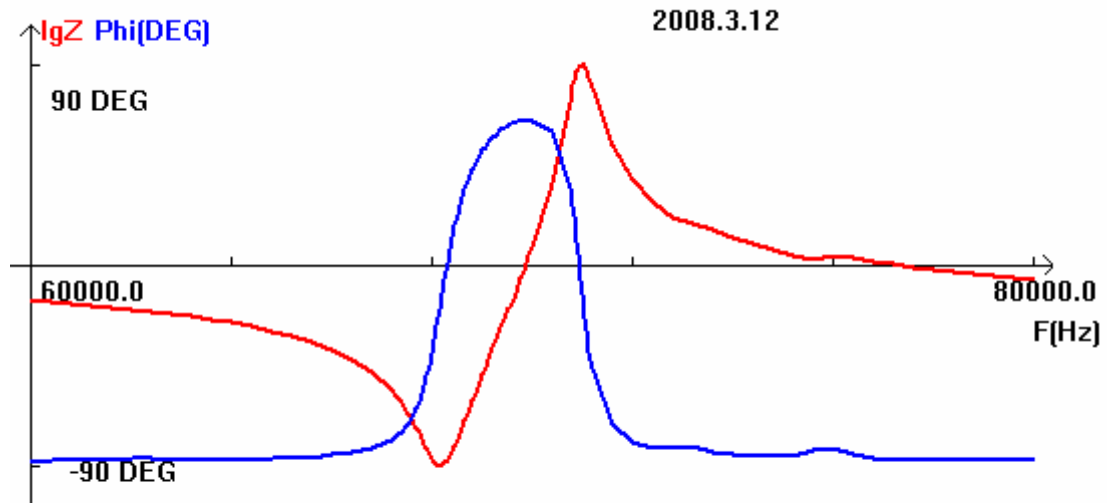

■ MEASURING PROCEDURE

The node held with a measuring terminal, the resonant frequency and resonant impedance are measured in the constant-voltage circuit.

