

1.MECHANICAL DIMENSIONS (外形尺寸):

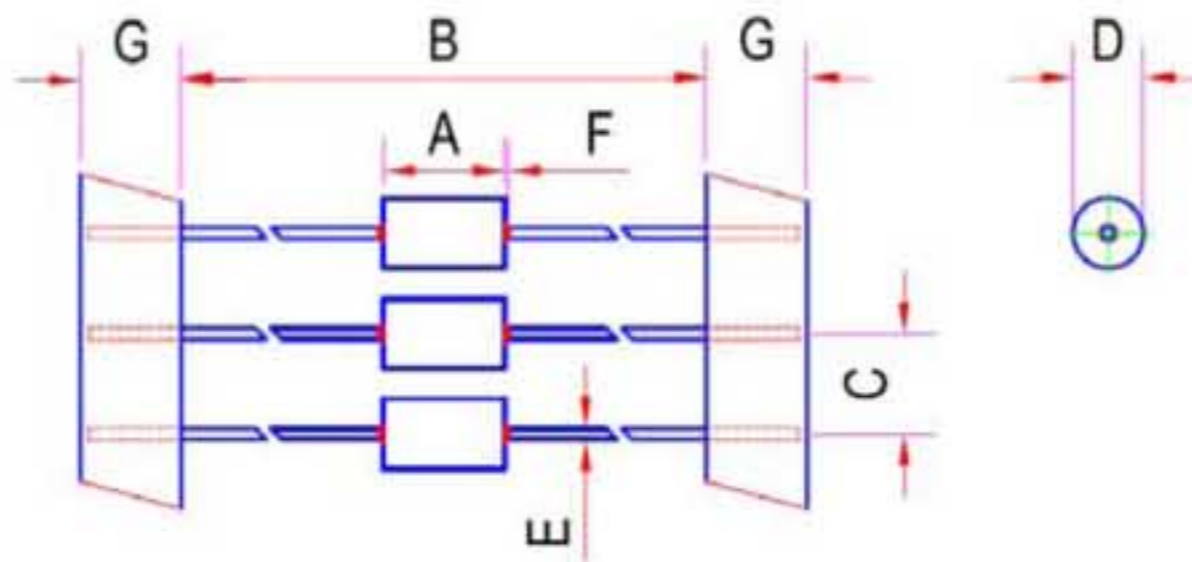
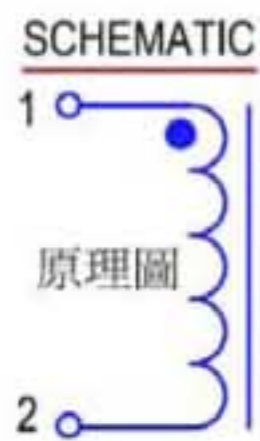

Item 項目	Spec.(mm) (規格)	Typ. (參考值)
A	5.0 +- 0.3	5.06
B	52.0 +- 1.0	
C	5.0 +- 0.5	
D	3.5 +- 0.20	3.54
E	0.65 +- 0.05	
F	1.0 MAX	0.6
G	6.0 +- 1.0	6.05
H		
I		
J		
Marking (印字):		

2.ELECTRICAL CHARACTERISTICS (電特性要求):

Item (項目)	Specifications (規格)	Typ.(參考值)	Test equipments (測試設備):
Z	30Ω MIN	51.3Ω	HP4291B RF MPEDANCE ANALYZER
Test Freq.	@25MHz		HP4291B RF MPEDANCE ANALYZER
Z	60Ω MIN	83Ω	HP4291B RF MPEDANCE ANALYZER
Test Freq.	@100MHz		HP4291B RF MPEDANCE ANALYZER
Turns	0.5Ts		
Ope.Temp.	-20 TO 80°C		HC-D3M TEMP. & HUMIDITY CHAMBER
Weight	0.3g/pcs		

Rev.	Date	Description	Remark
YUBRIGHT		YUBRIGHT CO., LTD.	P/N BDC-0305.060100
Title		BEAD COILS	Dwg. No. BDC030506010001
Date	20100202	Rev. A	RoHS <input checked="" type="checkbox"/>
File	MNT017	Drw. b37	App. b37

Unless otherwise specified, demensions are in millimeters.